



NEW!



ND30

- METER OF POWER NETWORK PARAMETERS

- **Measurement and recording** of 54 power network parameters, including **current and voltage harmonics up to 51st**, in 1-phase 2-wire or 3-phase 3 or 4-wire balanced and unbalanced systems.
- **Graphical color display:** LCD TFT 3,5", 320 x 240 pixels, **fully configurable by a user** (10 vies, 8 parameters in each)
- Indications include the values of programmed ratios.
- Memory of minimum and maximum values.
- 2 configurable alarm outputs.
- Optional: analog output 0/4...20 mA and 2 PT 100 inputs.
- Data archiving in the internal memory 8 GB (option).
- Digital output RS-485 - MODBUS protocol.
- **Modern and user-friendly Ethernet interface** 10/100 BASE-T (option):
 - protocol: MODBUS TCP/IP, HTTP, FTP,
 - services: www server, ftp server, DHCP client.
- Programming of parameters using **free eCon software**.
- Battery backup RTC.
- Overall dimensions: 96 x 96 x 77 mm.

EXAMPLE OF APPLICATION

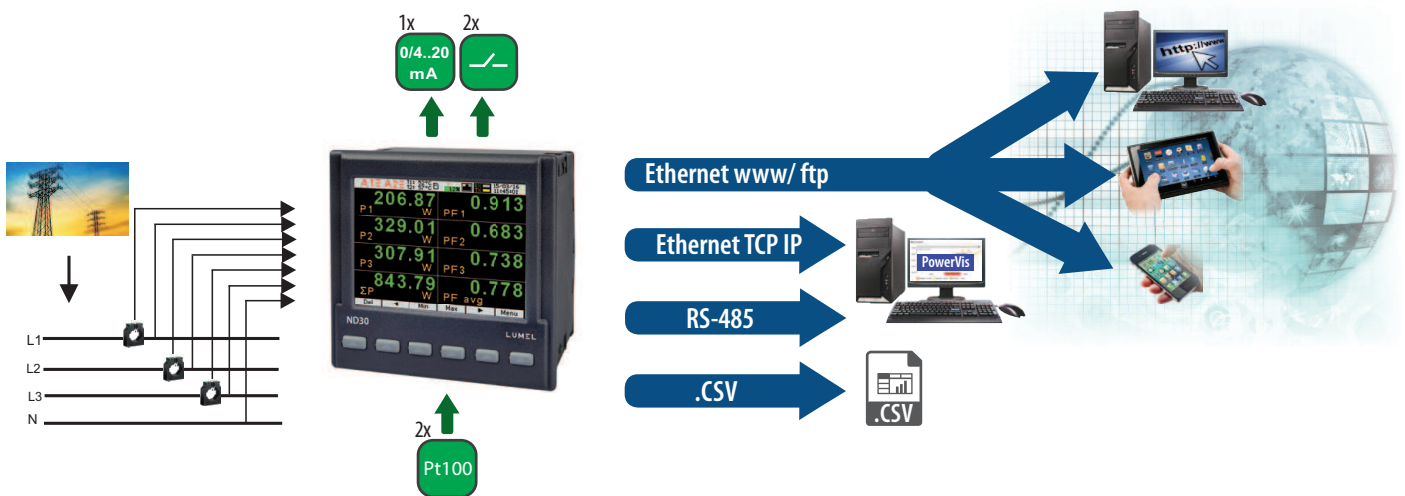

MEASUREMENT AND VISUALIZATION OF POWER NETWORK PARAMETERS

- phase voltages: U_1, U_2, U_3
- phase-to-phase voltages: U_{12}, U_{23}, U_{31}
- phase currents I_1, I_2, I_3
- active phase powers: P_1, P_2, P_3
- reactive phase powers: Q_1, Q_2, Q_3
- apparent phase powers: S_1, S_2, S_3
- active power factors: PF_1, PF_2, PF_3
- reactive/active power factors: $tg\phi_1, tg\phi_2, tg\phi_3$
- active, reactive and apparent 3-phase power: P, Q, S
- mean 3-phase power factors: $PF, tg\phi$
- frequency f
- mean 3-phase voltage: U_s
- mean phase-to-phase voltage: U_{mf}
- mean 3-phase current: I_s
- 15, 30, 60 minutes' mean active power: P_{demand}
- mean apparent power S_{demand}
- average current I_{demand}
- active, reactive and apparent 3-phase energy: EnP, EnQ, EnS
- active, reactive and apparent energy from external counter: $EnPE$
- total harmonic content coefficients for phase voltages and currents $THD_{U1}, THD_{U2}, THD_{U3}, THD_{I1}, THD_{I2}, THD_{I3}$ and for 3-phase voltages and currents THD_U, THD_I
- harmonics for current and phase voltage up to 51 st!

FEATURES	INPUTS	OUTPUTS	GALVANIC ISOLATION

TECHNICAL DATA

MEASURING RANGE

Measured value	Measuring range	L1	L2	L3	Σ	Class (*) / Basic error (*) class relative to the measured value acc. to EN61557-12
Current I/5 A 1 A~ 5 A~	0.010 ..0.100..1.200 A (tr_I=1) 0.050 ..0.500.. 6.000 A (tr_I=1) ...20.00 kA (tr_I≠1)	•	•	•		Class 0.2
Voltage L-N 57.7 V~ 230 V~ 400 V~	5.7..11.5 ..70.0 V (tr_U=1) 23.0..46 .. 276.0 V (tr_U=1) 40.0..80 .. 480.0 V (tr_U=1) ...480.0 kV (tr_U≠1)	•	•	•		Class 0.2
Voltage L-L 100 V~ 400 V~ 690 V~	10.0 ..20.. 120.0 V (tr_U=1) 40.0..80 .. 480.0 V (tr_U=1) 69.0..138 .. 830.0 V (tr_U=1) ...830.0 kV (tr_U≠1)	•	•	•		Class 0.5
Active power P _r , average active power P _{dr}	.. (-)1999.9 W ..(-)1999.9 MW (tr_U≠1.tr_I≠1)	•	•	•	•	Class 0.5
Reactive power Q _i	.. (-)1999.9 Var ..(-)1999.9 MVar (tr_U≠1.tr_I≠1)	•	•	•	•	Class 1
Apparent power S _r , average apparent power S _{dr}	..1999.9 VA ..1999.9 MVA (tr_U≠1.tr_I≠1)	•	•	•	•	Class 0.5
Active energy EnP (imported or exported)	.. (-)1999.9 Wh ..(-)1999.9 MWh (tr_U≠1.tr_I≠1)				•	Class 0.5
Reactive energy EnQ (inductive or capacitive)	.. (-)1999.9 Varh ..(-)1999.9 MVarh (tr_U≠1.tr_I≠1)				•	Class 2
Apparent energy EnS	.. 1999.9 VAh ..1999.9 MVAh (tr_U≠1.tr_I≠1)				•	Class 0.5
Active power factor PF _i	-1.00 ..0 ..1.00	•	•	•	•	± 0.01 of basic error
Coefficient tgφ _i (ratio of reactive power to active power)	-1.20 ..0 ..1.20	•	•	•	•	± 0.01 of basic error
Frequency f	45.00..65.00 Hz				•	Class 0.1
Total harmonic distortion of voltage THDU and current THDI	0.0 ..100.0 %	•	•	•	•	Class 5 50 / 60 Hz
Amplitudes of the voltage U _{h1} ... U _{h50} and current I _{h1} ... I _{h50}	0.0 ..100.0 %	•	•	•		Class 5 50 / 60 Hz

tr_I, tr_U – ratio of current and voltage transformer

INPUTS

Input type	Properties
Input PT100 (T1, T2) - option	2 x Pt100, 2-wire, -50...400°C, basic error 0.5 %

DIGITAL INTERFACE

Interface type	Transmission protocol	Remarks
RS-485	Modbus RTU 8N2,8E1,8O1,8N1 Address 1..247	baud rate: 4.8, 9.6, 19.2 38.4, 57.6, 115.2 kbit/s
Ethernet 10/100 Base-T -option	Modbus TCP,HTTP,FTP	WWW server, FTP server, DHCP client

EXTERNAL FEATURES

Readout field	graphic color display LCD TFT 3,5", 320 x 240 pixels	
Overall dimensions	96 x 96 x 77 mm	mounting hole 92.5 x 92.5 mm
Weight	0.3 kg	
Protection grade	from frontal side: IP65	from terminal side: IP20

RATED OPERATING CONDITIONS

Supply voltage	85...253 V a.c. (40...400 Hz) or 90...300 V d.c.	power consumption ≤ 6 VA
Power consumption	in voltage circuit ≤ 0.2 VA	in current circuit ≤ 0.1 VA
Input signal	0...0.1...1.2 In; 0.1...0.2...1.2 Un for current, voltage, PF, tg ϕ	frequency 45...50...60...65 Hz, sinusoidal (THD $\leq 8\%$)
Power factor	-1...0...1	
Preheating time	5 min.	
Ambient temperature	-10...23...55°C, class K55 acc. to EN61557-12	
Humidity	0...40...65...95%	without condensation
Operating position	any	
External magnetic field	$\leq 40...400$ A/m d.c.	≤ 3 A/m a.c. 50/60 Hz
Short-term overload	voltage input: 2 Un (5 sec.)	current input 50 A (1 sec.)
Admissible crest factor	current: 2	voltage: 2
Additional error (in % of the intrinsic error)		from ambient temperature change: $< 50\% / 10^\circ\text{C}$

SAFETY AND COMPABILITY REQUIREMENTS

Electromagnetic compatibility	noise immunity	acc. to EN 61000-6-2
	noise emissions	acc. to EN 61000-6-4
Isolation insured by the casing	double	acc. to EN 61010-1
Isolation between circuits	basic	acc. to EN 61010-1
Pollution level	2	acc. to EN 61010-1
Installation category	III	acc. to EN 61010-1
Maximal phase-to-earth voltage	<ul style="list-style-type: none"> for supply circuit and relay outputs 300 V for measuring input 500 V for circuits of RS-485, Ethernet, pulse input and output, analog outputs: 50 V 	acc. to EN 61010-1
Altitude a.s.l.	< 2000 m	

CONNECTION DIAGRAMS

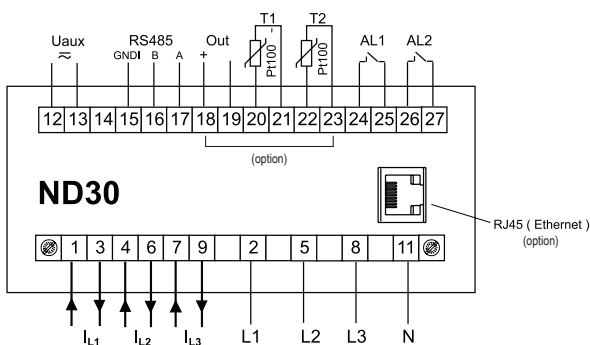

Description of meter connections strips

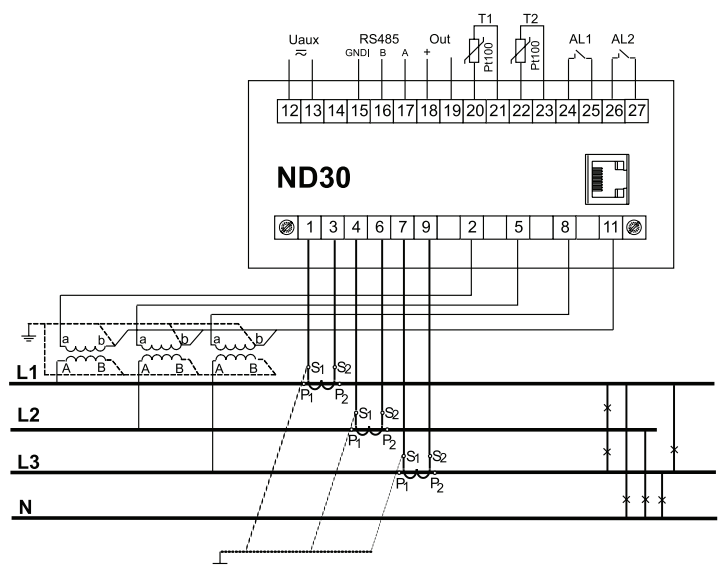

Indirect measurement in 4-wire network - connection of input signals

ORDERING CODE

Meter ND30 -	X	X	X	XX	X	X
Input voltage (phase/phase-to-phase) Un:						
3 x 57.7/ 100 V, 3x 230/ 400 V	1					
3 x 110/ 190 V, 3 x 400/ 690 V	2					
Additional outputs /inputs:						
2 relays	1					
2 relays, 1 analog output, 2 inputs PT100	2					
Interface:						
RS-485			1			
RS-485 and Ethernet, internal memory			2			
Version:						
standard				00		
custom-made*				XX		
Language:						
Polish					P	
English					E	
other*					X	
Acceptance tests:						
without additional quality requirements						0
with an extra quality inspection certificate						1
acc.to customer's request*						X

Order example:

The code: **ND30 - 1 2 2 00 E 0** means:

ND30 - meter ND30

1 - input voltage 3 x 57.7/ 100 V, 3x 230/ 400 V

2 - 2 relays, 1 analog output, 2 inputs PT100

2 - RS-485 and Ethernet, internal memory

00 - standard version

E - user's manual in English

0 - without additional quality requirements.

* only after agreeing with the manufacturer

SEE ALSO:



ND40 - power network analyzer/ recorder



RE92 - dual loop controller



P30U - universal transducer of temperature and standard signals



KS31 - Digital synchronizing unit



N43 - rail mounted 3-phase power network meter



P43 - 3-phase transducer of power network parameters



ND1 - analyser of network parameters



Current transformers from 5 A up to 6 kA



Free **eCON** software

For more information about Lumel products please visit our website:

www.lumel.com.pl



Join us at Facebook!

